

EN

INSTRUCTIONS
MULTIFUNCTION MEASURING
METER

Table of contents

Information on the use of these instructions 2

Safety 2

Information about the device..... 4

Transport and storage..... 7

Operation 7

MultiMeasure Mobile app..... 20

Maintenance and repair 29

Errors and faults 30

Disposal 31

Declaration of conformity 31

Information on the use of these instructions

Symbols

 **Warning**
 This signal word indicates a hazard with an average risk level which, if not avoided, can result in serious injury or death.

 **Warning of electrical voltage**
 This symbol indicates dangers to the life and health of persons due to electrical voltage.

 **Caution**
 This signal word indicates a hazard with a low risk level which, if not avoided, can result in minor or moderate injury.

Notice
 This signal word indicates important information (e.g. material damage), but does not indicate hazards.

 **Info**
 Information marked with this symbol helps you to carry out your tasks quickly and safely.

 **Follow the manual**
 Information marked with this symbol indicates that the instructions must be observed.

You can download the current version of these instructions via the following link:



T4000



<https://hub.trotec.com/?id=47702>

Safety

Read this manual carefully before starting or using the device. Always store the manual in the immediate vicinity of the device or its site of use.

 **Warning**
Read all safety warnings and all instructions.
 Failure to follow the warnings and instructions may result in electric shock, fire and/or serious injury.
Save all warnings and instructions for future reference.

- Do not use the device in potentially explosive rooms or areas and do not install it there.
- Do not use the device in an aggressive atmosphere.
- Protect the device from permanent direct sunlight.
- Do not open the device.
- Do not remove any safety signs, stickers or labels from the device. Keep all safety signs, stickers and labels in legible condition.
- Use batteries of type LR06 (AA).
- Never charge batteries that cannot be recharged.
- Different types of batteries and new and used batteries must not be used together.
- Insert the batteries into the battery compartment according to the correct polarity.
- Remove discharged batteries. Batteries contain materials hazardous to the environment. Dispose of the batteries according to the national regulations.
- Remove the batteries from the device if you will not be using the device for a longer period of time.
- Never short-circuit the terminals of batteries!
- Do not swallow batteries! If a battery is swallowed, it can cause severe internal burns within 2 hours! These burns can lead to death!
- If you think batteries might have been swallowed or otherwise entered the body, seek medical attention immediately!

- Keep new and used batteries and an open battery compartment away from children.
- Never measure live parts.
- Check accessories and connection parts for possible damage prior to every use of the device. Do not use any defective devices or device parts.

Intended use

Use the multifunctional measuring meter in combination with the sensors provided for preventive maintenance and damage analysis. Observe and comply with the storage and operating conditions according to the Technical data chapter.

Intended use comprises:

- the analysis of:
 - supply and exhaust air flows
 - fluctuations in relative humidity
 - condensate formation
 - poor machine cooling
 - porous seals
 - heat build-up and temperature fluctuations
 - excessively dry or damp materials
- leak detection with trace gas

Any use other than the intended use is regarded as misuse.

Reasonably foreseeable misuse

Do not use the device and accessories in potentially explosive atmospheres or aggressive liquids.

Avoid exposing the device to moisture.

Any unauthorised changes, modifications or alterations to the device are forbidden.

Personnel qualification

People who use this device must:

- take measures to protect themselves from direct contact with live parts.
- have read and understood the instructions, especially the Safety chapter.

Residual risks



Warning

There is a danger of suffocation for children due to packaging material! Keep packaging films and parts away from children. There is a risk of death due to suffocation.



Warning of electrical voltage

There is a risk of a short-circuit due to liquids penetrating the housing!
Do not immerse the device and the accessories in water. Make sure that no water or other liquids can enter the housing.



Warning of electrical voltage

Work on the electrical components must only be carried out by an authorised specialist company!



Warning

The device is not a toy and does not belong in the hands of children.



Warning

Dangers can occur at the device when it is used by untrained people in an unprofessional or improper way! Observe the personnel qualifications!



Caution

Keep a sufficient distance from heat sources.

Notice

To prevent damages to the device, do not expose it to extreme temperatures, extreme humidity or moisture.

Notice

Do not use abrasive cleaners or solvents to clean the device.

Information about the device

Device description

The T4000 multifunction measuring meter is used for carrying out detailed analysis in the fields of material and construction diagnostics. For this purpose, the device has an SDI and a BNC port to which you can connect any compatible sensor (SDI) or measuring electrodes (BNC).

The intelligent technology of the T4000 automatically recognises the connected SDI sensor. Depending on the sensor construction, it is calibrated to the prevailing surrounding conditions after connection.

The device can be operated both using the control buttons and the touchscreen display.

Using the Bluetooth function, you can connect the device to a mobile terminal device and read and analyse your measurement results with the optional MultiMeasure Mobile application.

The device is designed to operate on batteries. However, it can also be connected to a suitable power source via a USB-C cable and thus used in mains operation if required.

With a microSD card, recordings can optionally be saved and then transferred to a computer.

The multifunction measuring meters T4000 and T3000 are compatible with each other. Using adapter cables, you can connect the SDI sensors of the T3000 series to the T4000 and vice versa.

The following transmission cables are available for the T4000 series:

Name	Function
TC10	T4000 SDI sensors to T3000
TC35	T3000 SDI sensors to T4000
TC40	T4000 SDI sensors to T4000
TC45	T4000 SDI sensors to T4000 with 3-metre supply cable

Device depiction

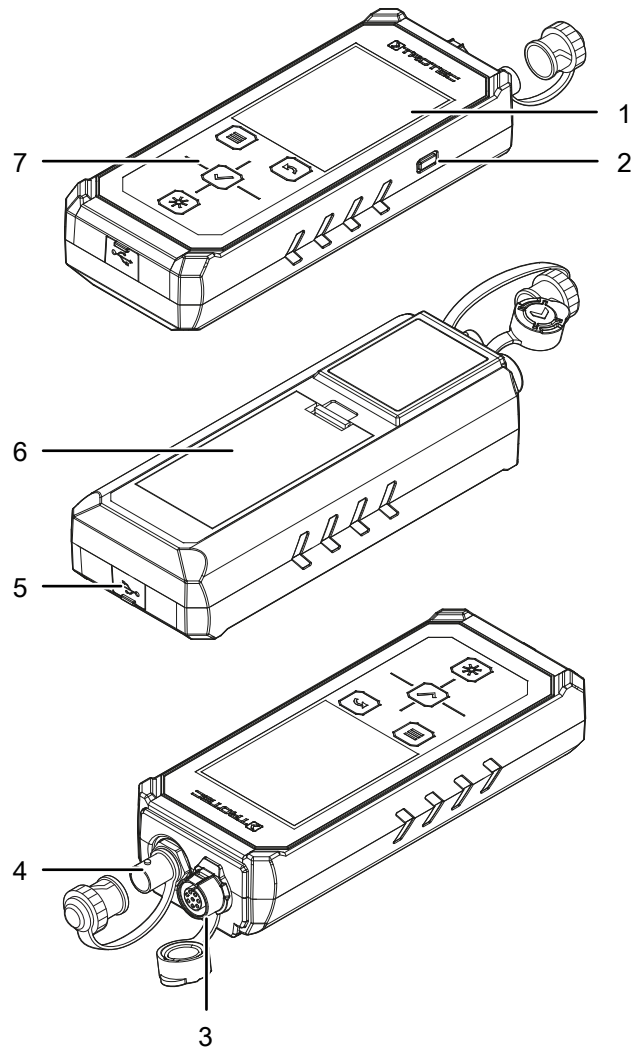

No.	Designation
1	Touchscreen display
2	Power button
3	SDI connection (5-pin)
4	BNC connection
5	USB-C port
6	Battery compartment with cover
7	Operating elements

Operating elements

The device can be operated both using these operating elements and the touchscreen display.

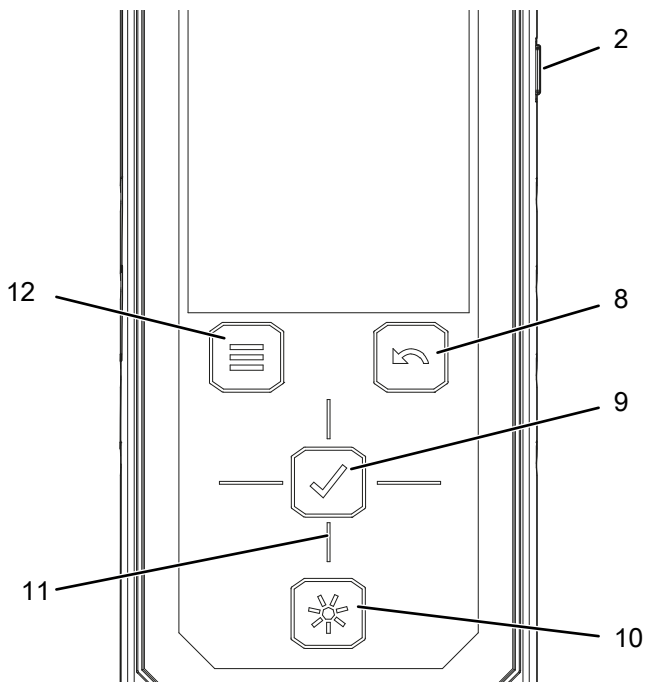

No.	Operating element	Function
2	<i>Power</i> button	Switching on the device: press for approx. 2 s Activating or deactivating large print: press for approx. 1 s Activating or deactivation key lock: press for approx. 2 s Switching the device off: press for approx. 5 s
8	<i>Back</i> button	Opening the previous menu
9	<i>Confirm</i> button	Opening the submenu Confirming settings
10	<i>Illumination</i> button	Adjusting the display brightness: press briefly Taking a screenshot: press and hold
11	Cross control with <i>Up</i> , <i>Down</i> , <i>Left</i> , <i>Right</i> buttons	Navigating through menus Setting values
12	<i>Main menu</i> button	Opening the main menu

For safety reasons, some options can only be selected and configured by using the cross control and the *Confirm* button (9) (e.g. date and time in the *Settings* menu).

Display

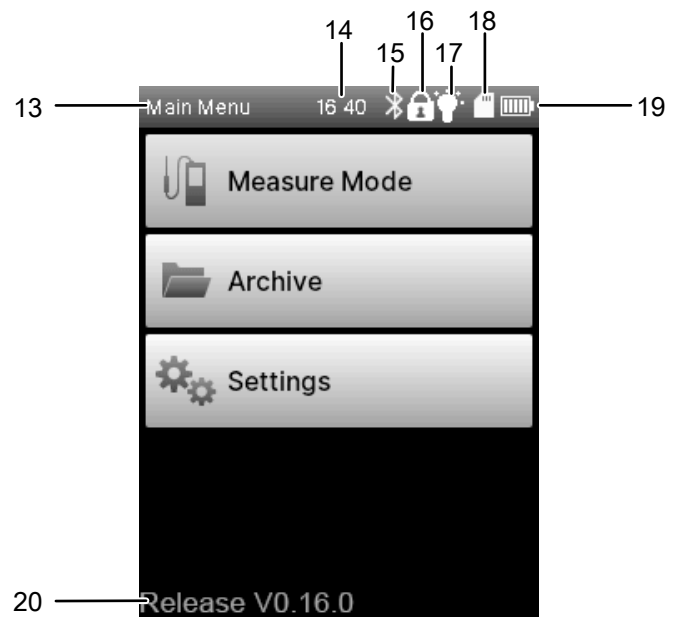

No.	Indication	Meaning
13	<i>Title</i>	Name of the current screen or connected sensor type
14	<i>Time</i>	Current time
15	<i>Bluetooth</i>	Bluetooth enabled
16	<i>Padlock</i>	Key lock activated
17	<i>Lamp</i>	Additional display illumination activated
18	<i>Memory card</i>	microSD card inserted
19	<i>Battery</i>	Battery charge level
20	<i>Footer</i>	Software version number

Technical data

Parameter	Value	
Model	T4000	
Dimensions (length x width x height)	approx. 177 x 62 x 34 mm	
Operating range		
Operating temperature	0 °C to +50 °C	
Relative humidity	< 90 % or < 20 g/m ³ (non-condensing)	
Height above sea level (SL)	max. 3000 m	
Storage		
Relative humidity	< 95 % (non-condensing)	
Ambient temperature	- 20 °C to +60 °C	
Power supply		
Battery	4 x Alkaline LR6 AA, 1.5 V batteries	
Optional power supply	5 V USB-C	
Power input, active	approx. 400 mW	
Battery lifespan, passive	approx. 1 year	
Battery lifespan, active	at least 24 h	
Bluetooth		
Frequency	2.4 GHz	
Max. transmission power	-24 dBm	
Compatibility		
Sensors*	SDI sensors (digital)	Air temperature and humidity Material temperature Material moisture Air current H ₂ trace gas detection
	BNC electrodes	Material moisture (construction materials and wood) according to the resistance measuring method
Measured value memory	internal memory, expandable with microSD card	
Amount of tiles in the grid	max. 50 x 40 (max. amount of grid fields in one measurement)	
Real time clock with programmed calendar		
Trace gas sensor (optional)	TS810/TS820 SDI	
Response sensitivity	1 ppm H ₂	
Measuring range	10 to 1000 ppm H ₂	
Response time	< 1 s	
Pore size at stainless steel sinter filter	> 50 µm	
Power supply	5 – 5.5 V	
Ambient temperature		
Operation	10 °C to +60 °C	
Storage	-20 °C to +50 °C	
Relative humidity	< 95 % (non-condensing)	

* Data changes reserved.

Scope of delivery

- 1 x Multifunction measuring meter T4000
- 1 x Display protection film
- 1 x Factory test certificate
- 1 x MultiMeasure Mobile app for download, see Operation chapter
- 1 x Manual

Transport and storage

Notice

If you store or transport the device improperly, the device may be damaged.

Note the information regarding transport and storage of the device.

Transport

To safely transport the multifunction measuring meter and accessories, use the optional MultiMeasure transport case recommended by Trotec. Otherwise, protect the device during use and transport with an optional device bag. Contact your Trotec customer service.

Storage

When the device is not being used, observe the following storage conditions:

- dry and protected from frost and heat
- protected from dust and direct sunlight
- at the temperature specified in the technical data
- Batteries are removed from the device

Operation

Inserting a microSD card (optional)

A microSD card can be inserted into the device to expand the internal measured value memory and transfer measured values to a computer. Please proceed as follows:



Caution

Make sure that the surface of the device is dry and the device is switched off.

1. Open the cover of the battery compartment (6).

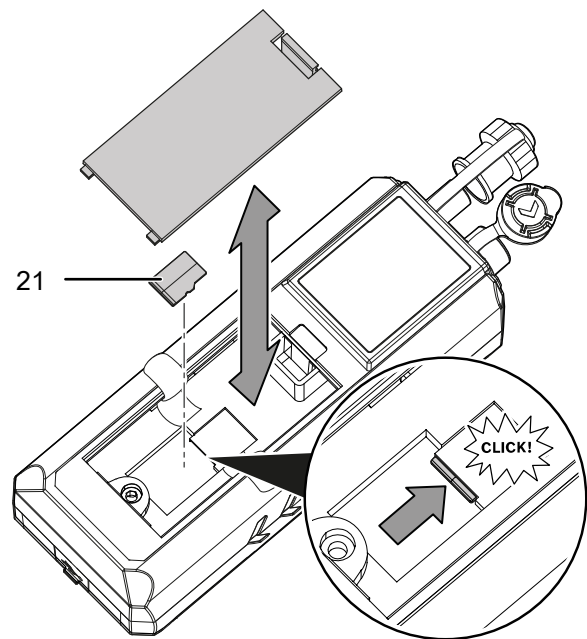

2. Insert the microSD card (21) into the slot provided as shown.
 - ⇒ You will hear a clicking sound and feel the microSD card click into place.
3. Refit the battery compartment cover or continue with inserting the batteries if required.

Inserting the batteries

Insert the batteries into the device before first use.



Caution

Make sure that the surface of the device is dry and the device is switched off.

1. Open the cover of the battery compartment (6).

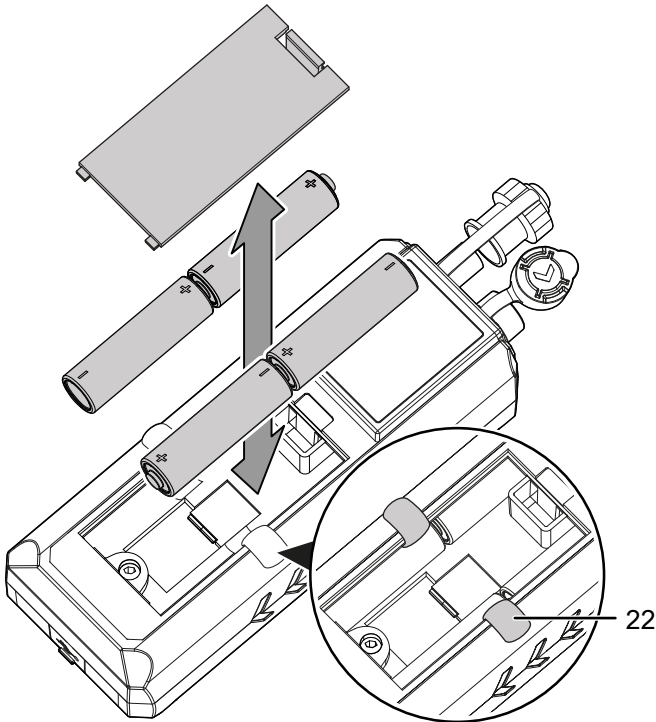

2. When inserting the batteries, make sure that the integrated pull tab (22) is positioned as shown.
 - ⇒ It makes it easier to remove the batteries.
3. Insert the batteries with correct polarity.
4. Insert the cover of the battery compartment.
 - ⇒ The device can now be switched on.

Switching the device on

1. Press and hold the *Power* button (2) for approx. 2 seconds.
 - ⇒ An acoustic confirmation signal is emitted.
 - ⇒ After approx. 3 seconds, the colour display will be switched on. The device is ready to go as soon as the main menu is shown.

Notice

Note that moving from a cold area to a warm area can lead to condensation forming on the device's circuit board. This physical and unavoidable effect can falsify the measurement. In this case, the display shows either no measured values or they are incorrect. Wait a few minutes until the device has become adjusted to the changed conditions before carrying out a measurement.

Key lock

1. Press the *Power* button (2) for approx. 1 second during operation.
 - ⇒ Key lock is activated.
 - ⇒ The *Padlock* indication (16) is shown on the display.
2. Press the *Power* button (2) for approx. 1 second again.
 - ⇒ Key lock is no longer activated.
 - ⇒ The *Padlock* indication (16) disappears.

Main menu

You can open the following submenus from the main menu:

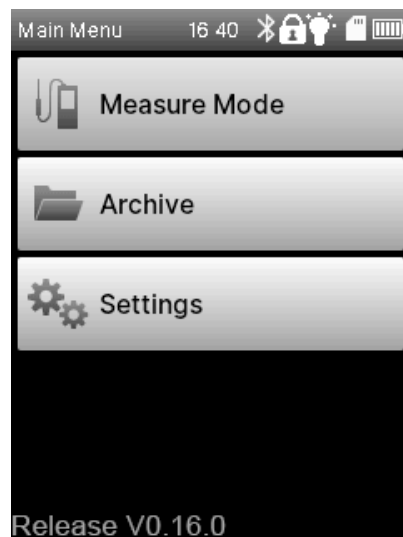

Submenu	Function
<i>Measure Mode</i>	Carry out measurements
<i>Archive</i>	Open archived measured values
<i>Settings</i>	Make device settings

Selecting the measuring mode

In the *Measure Mode* submenu, you can select the appropriate measurement mode for the connected sensor:



Measuring method	Function
<i>Wood Humidity</i>	Measure moisture in wood (with BNC electrode)
<i>Building Humidity</i>	Measure moisture in walls and floors (with SDI or BNC electrodes)
<i>Airflow</i>	Measure air/gas flows (with SDI sensor)
<i>Air Humidity/ Temperature</i>	Measure humidity and air temperature (with SDI sensor)
<i>Temperature</i>	Measure temperature (with SDI sensor)
<i>Hydrogen</i>	Measure hydrogen content (trace gas; with SDI sensor)

Activating large print

The current measured values shown in the upper half of the display can also be displayed in large print.

1. Briefly press the *Power* button (2) in any measuring mode screen.

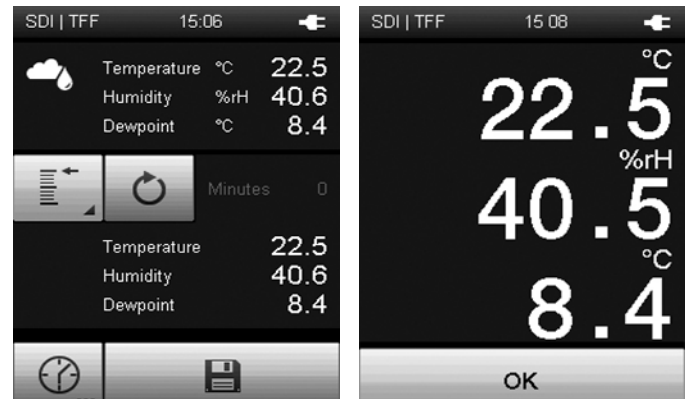

2. To exit the large print display, press the *Power* button (2) once again.



Info

When the key lock is enabled, large print cannot be activated or deactivated.

Wood moisture measuring mode

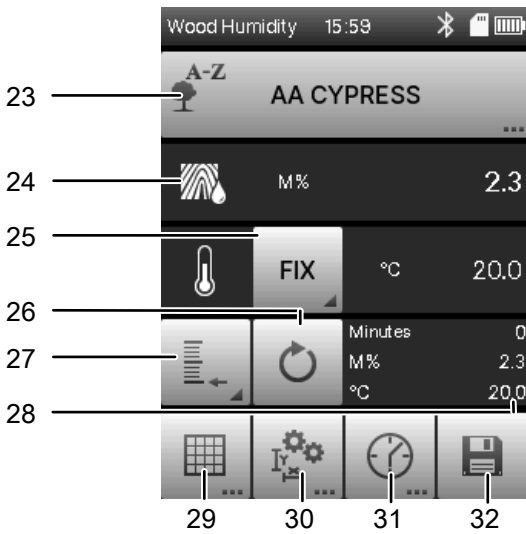

Item	Designation	Function
23	<i>Wood type selection</i>	Opens the menu for selecting the wood type. See below for a description of how to set the wood type.
24	<i>Wood moisture</i>	Shows the wood moisture as a mass percentage (relative mass proportion of the humidity to the total mass).
25	<i>Temperature reference</i>	Opens the menu for selecting the internal temperature sensor (INT) or for entering a fixed temperature value (FIX). The measured or manually specified temperature value is shown on the right.
26	<i>Reset</i>	Resets the measured values displayed in (28) to zero.
27	<i>MAX/MIN</i>	Opens the menu for selecting the indication of measured values. Minimum: Indicates the smallest detected measured value from a measuring period. Maximum: Indicates the largest detected measured value from a measuring period. Average: Indicates the average value of all detected measured values from a measuring period. Hold: Pauses the current detected measured value and shows it continually (when this option is selected). Off: Switches off the indication of measured values in (28).

Item	Designation	Function
28	<i>Wood moisture reference values</i>	Measured value indication according to selection in (27): Minute: Duration of the measured interval M%: Shows the measured value (e.g. as average value) as a mass percentage. °C: Shows the measured (INT) or manually specified temperature value (FIX).
29	<i>Grid measurement</i>	Opens the menu for carrying out a grid measurement (see section <i>Carrying out a grid measurement</i>).
30	<i>Measuring range</i>	Opens the menu for setting the measuring range in height x width (edge lengths) and their activation/deactivation as well as the specified temperature value (FIX) (see section <i>Setting the measuring range</i>).
31	<i>Recording</i>	Opens the menu for setting a fixed recording duration for an automatic measurement (see section <i>Carry out a continuous measurement</i>).
32	<i>Save</i>	Saves the measured values in the archive.

To change the wood type, please proceed as follows:

1. Tap the displayed type of wood (23).
2. Press the *Confirm* button (9) to activate the *Wood type* input box.
3. Press the *Up* or *Down* button on the cross control (11) to select the initial letter of the desired type of wood.
4. Press the *Right* button to select additional letters of the desired type of wood if necessary.
5. Confirm the setting by pressing the *Confirm* button (9).
6. Use the *Down* button to navigate through the search result list or use the *Left* and *Right* buttons to scroll forwards or backwards through the "Wood type" list page by page.
7. Confirm the selected wood type by pressing the *Confirm* button (9).

Building moisture measuring mode

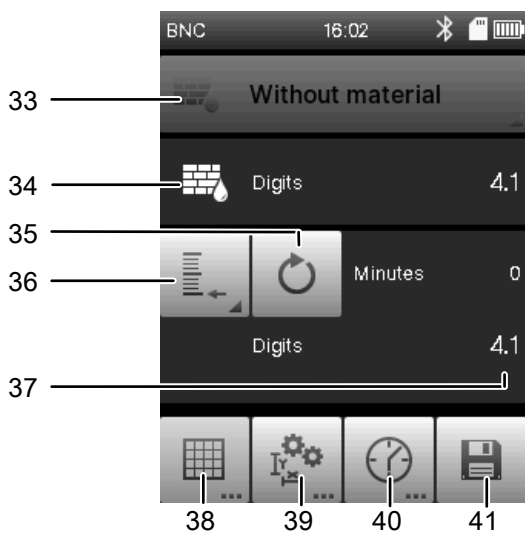

Notice

When using BNC electrodes, the measured value is shown as the dimensionless unit *digits*.

When using dielectric measuring SDI sensors, the measured value is shown as *digits*, *M%* or *CM%*.

Item	Designation	Function
33	<i>Construction material selection</i>	<p>Opens the menu for selecting the construction material:</p> <p>Without material: a non-destructive, indicative (<i>digit</i>) measurement is carried out</p> <p>Anhydrite floor: A building moisture measurement for anhydrite screed is carried out (with SDI sensor TS660SDI/TS670SDI only). The measurement results (indicative) in M% and CM% are calculated with an equation which is suitable for this material.</p> <p>Cement floor: building moisture measurement for cementitious screed (with SDI sensor TS660/TS670SDI only). The measurement results (indicative) in M% and CM% are calculated with an equation which is suitable for this material</p>
34	<i>Building moisture</i>	<p>Indicates the building moisture:</p> <p>digits: dimensionless display of the measured value (with BNC electrode):</p> <p>M%: indicates the measured value as a mass percentage (with SDI sensor TS660SDI/TS670SDI only)</p> <p>CM%: indicates the measured value according to the calcium carbide method (with SDI sensor TS660SDI/TS670SDI only)</p>

Item	Designation	Function
35	<i>Reset</i>	Resets the measured values displayed in (37) to zero.
36	<i>MAX/MIN</i>	<p>Opens the menu for selecting the indication of measured values.</p> <p>Minimum: Indicates the smallest detected measured value from a measuring period.</p> <p>Maximum: Indicates the largest detected measured value from a measuring period.</p> <p>Average: Indicates the average value of all detected measured values from a measuring period.</p> <p>Hold: Pauses the current detected measured value and shows it continually (when this option is selected).</p> <p>Off: Switches off the indication of measured values in (37).</p>
37	<i>Building moisture reference values</i>	<p>Measured value indication according to selection in (36):</p> <p>Minute: Duration of the measured interval</p> <p>M%: Shows the measured value (e.g. as average value) as a mass percentage.</p> <p>CM%: Shows the measured value (e.g. as average value) according to the calcium carbide method.</p>
38	<i>Grid measurement</i>	Opens the menu for carrying out a grid measurement (see section <i>Building moisture – Grid measurement</i>).
39	<i>Measuring range</i>	Opens the menu for setting the measuring range in height x width (edge lengths) and their activation/deactivation as well as the specified alarm value (see section <i>Setting the measuring range</i>).
40	<i>Recording</i>	Opens the menu for setting a fixed recording duration for an automatic measurement (see section <i>Measuring mode building moisture – Automatic measurement</i>).
41	<i>Save</i>	Saves the measured values in the archive.

Humidity measuring mode

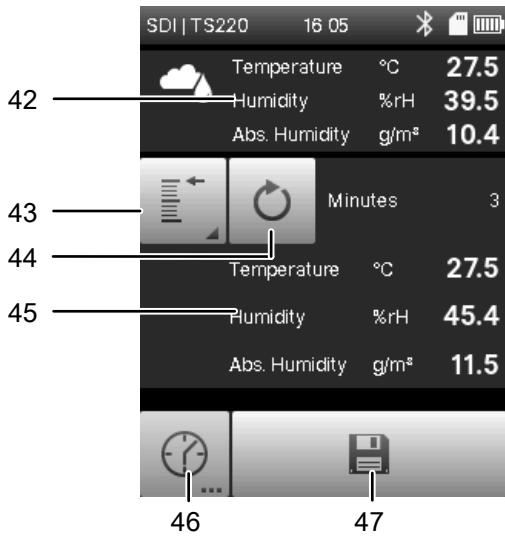

Item	Designation	Function
42	Measured humidity values	Shows the following measured values: Temperature: Temperature value in °C Humidity: Humidity in %RH (relative humidity) Dew point: Dew point in °C Critical dew point: Critical dew point in °C at 70%, 75% or 80% RH (user setting)
43	MAX/MIN	Specifies how measured values are displayed in (45): Minimum: Always shows the smallest detected measured value from a measuring period. Maximum: Always shows the largest detected measured value from a measuring period. Average: Shows the average value of all measured values which have been detected so far from a measuring period. Hold: Pauses the current detected measured value and shows it continually (when this option is selected). Off: Switches off the indication in (45).
44	Reset	Resets the measured values displayed in (45) to zero.
45	Humidity reference values	Shows the measured values according to the selection in (43).
46	Recording	Opens the menu for setting a fixed recording duration for an automatic measurement (see section <i>Carry out a continuous measurement</i>).
47	Save	Saves the measured values in the archive.

Carrying out a measurement



Info

Please note that moving from a cold area to a warm area can lead to condensation forming on the device's circuit board. This physical and unavoidable effect can falsify the measurement. In this case, the display shows either no measured values or they are incorrect. Wait a few minutes until the device has become adjusted to the changed conditions before carrying out a measurement.

After connecting a sensor and selecting the measuring mode, the measurement starts automatically.

Carrying out a measurement with SDI sensor (e.g. with TS670SDI humidity sensor)

1. Connect the device and the SDI sensor using the cable provided (48).
⇒ The plug perceptibly clicks into place on the connector.

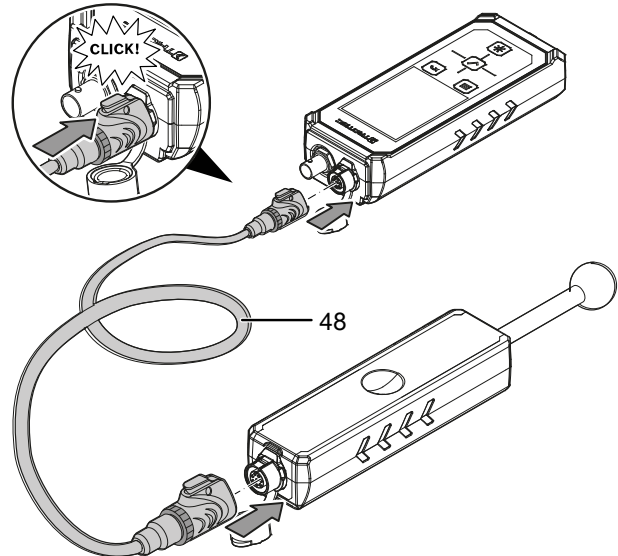

2. Select the suitable measuring mode, see "Setting the measuring mode".
3. Carry out the measurement.

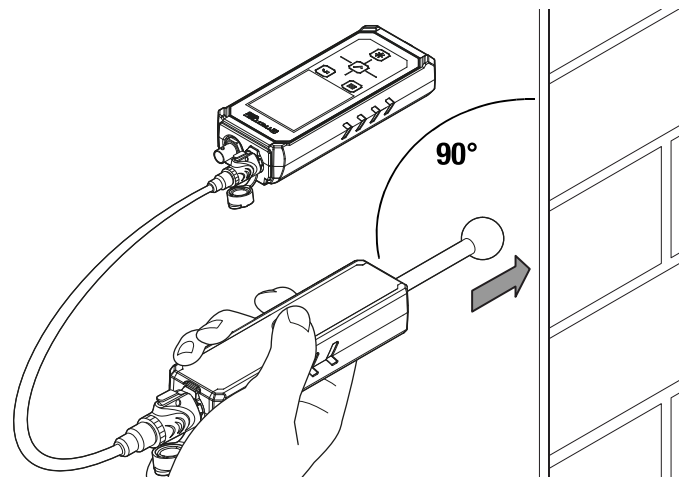

⇒ The measured values can be tracked on the device display or in the MultiMeasure Mobile app, see "Trotec MultiMeasure Mobile app".

Carrying out a measurement with BNC electrode (e.g. with TS12/200 measurement electrode)

1. Connect the device and the BNC sensor using the cable provided (49).

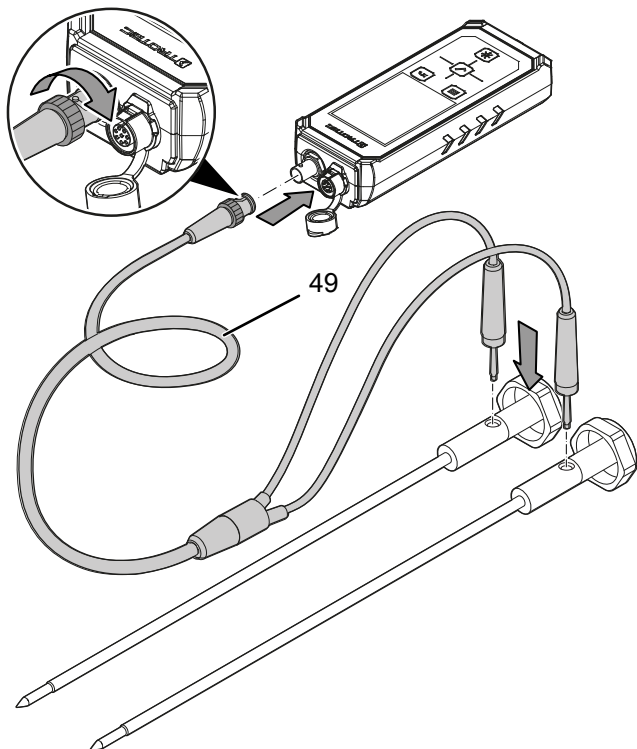

2. Select the suitable measuring mode, see "Setting the measuring mode".
3. Carry out the measurement.

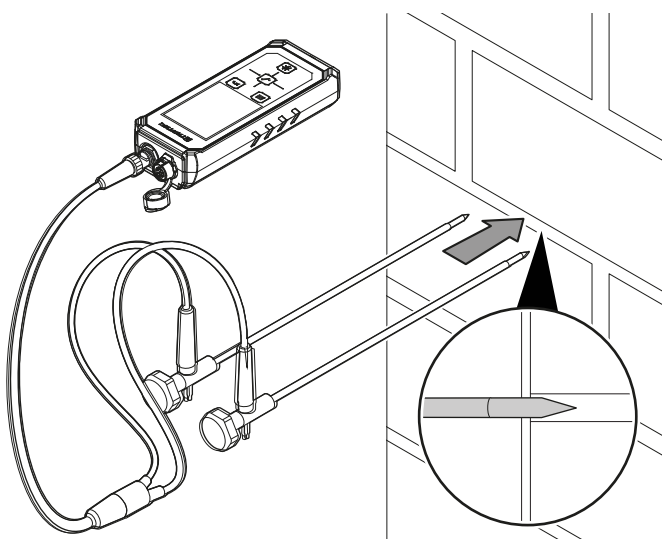

⇒ The measured values can be tracked on the device display or in the MultiMeasure Mobile app, see "Trotec MultiMeasure Mobile app".

Setting the measuring range

You can define the dimensions of the measuring range before performing a grid measurement.

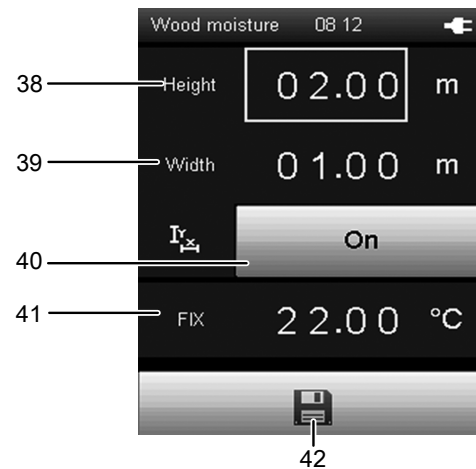

Item	Designation	Function
50	Height of measuring range	Total height of the grid area to be measured
51	Width of measuring range	Total width of the grid area to be measured
52	Activate measuring range	Activating ("On") or deactivating ("Off") the set measuring range during grid measurement When deactivated, you must specify the corresponding edge lengths of the grid area in the MultiMeasure app after grid measurement.
53	Temperature/ alarm	For wood moisture measurement: Choice between fixed temperature value for precise wood moisture calculation ("FIX") and integrated sensor ("INT") For building moisture measurement with SDI sensor: Limit value for the alarm signal of the dimensionless measuring unit "digits"
54	Save	Saves the settings.

To adjust the grid area dimensions, please proceed as follows:

1. Use the cross control or touch function to select the setting for the height or width of the grid.
2. Open the setting by pressing the *Confirm* button (9).
3. Use the *Up* and *Down* buttons of the cross control (11) to adjust the value.
4. Use the *Left* and *Right* buttons of the cross control to switch between the digits to be set.
5. Save the setting by pressing the *Confirm* button (9).
6. In the *Activate measuring range* selection menu, select whether the dimensions of the area should be used during grid measurement ("On") or not ("Off").

Carrying out a grid measurement

Use the grid measurement function to carry out a grid measurement (e.g. of a wall). The grid measurement can be carried out either with or without height and length details, but the grid is always used. Grid measurement is available for various sensors, e.g. wood or building moisture measurement, but not for all of them, depending on the application.

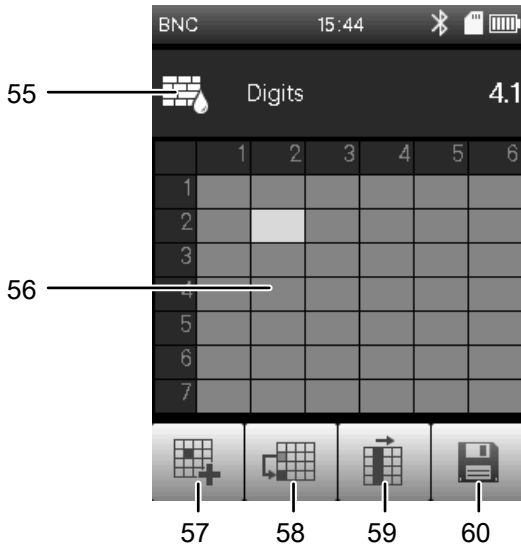

Item	Designation	Function
55	<i>Measured value</i>	dimensionless display of the measured value in digits: The lower the measured electric resistance, the higher the moisture content in the material and thus the digit value.
56	<i>Measuring grid</i>	Divides the measuring surface into a grid. The colour distribution from white (dry) to light blue (low moisture) and dark blue (wet) graphically shows the moisture distribution in the measured object.
57	<i>Enter measurement</i>	Enters the current measured value to the marked grid measuring spot. Afterwards, the grid measuring spot below will be selected.
58	<i>Skip</i>	Skips the grid measuring spot below the currently selected grid measuring spot and selects the grid measuring spot that follows afterwards. Use this function if no measurement can be made at this position because of a power cabinet or a window etc.
59	<i>Next column</i>	Skips to the start of the next column.
60	<i>Save</i>	Saves the measured values in the archive.

Please proceed as follows for grid measurement:

1. Press the *Confirm* button (9) to select the grid.
2. Use the cross control buttons (11) to select the grid measuring spot.
3. Press the *Confirm* button (9) to confirm the selected grid measuring spot.
⇒ The dimensionless measured value is recorded.
4. Use the cross control buttons to select the next grid measuring spot and repeat the process.

Carry out a continuous measurement

The recording function allows you to automatically record measured values at regular intervals over a desired period of time. The recording function is available for many sensors. The TS220 humidity sensor is shown by way of example.

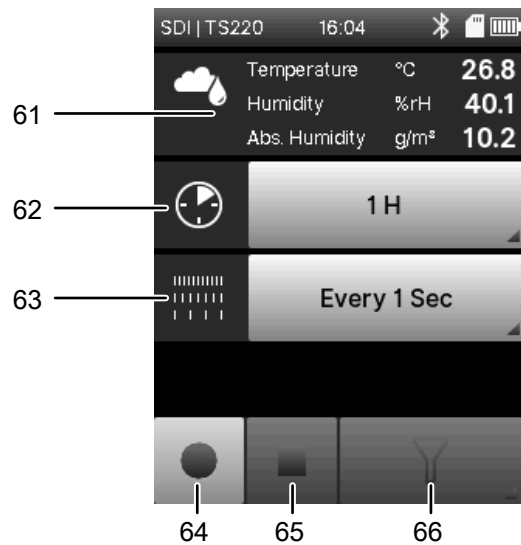

Item	Designation	Function
61	<i>Current measured values</i>	Indication of the current measured values
62	<i>Recording duration</i>	Opens a submenu with options for the duration of the recording.
63	<i>Recording interval</i>	Opens a submenu with options for the interval of the measured values to be saved.
64	<i>Start recording</i>	Starting a recording
65	<i>Stop recording</i>	Recording is stopped and the measured values are saved.
66	<i>Filter</i>	Opens a submenu for selecting the values to be displayed during recording

Please proceed as follows to perform a continuous measurement:

1. Open the measuring mode that is appropriate for your sensor.
2. Open the *Continuous measurement* submenu ((31, 40, 46).
3. Open the *Recording duration* submenu (62) and select the desired recording period.
4. Save your selection by pressing the *Confirm* button (9).
5. Open the *Recording interval* submenu (63) and select the desired time interval between the measured values to be saved.
6. Save your selection by pressing the *Confirm* button (9).
7. Press the *Start recording* button (64) to start recording.
 - ⇒ Recording begins.
 - ⇒ The recording symbol (64) is displayed in red.
 - ⇒ The screen for ongoing recordings opens.
 - ⇒ The elapsed and remaining time as well as the selected interval are displayed.



8. Open the *Filter* submenu (66) to change the view.
 - ⇒ A selection menu opens, allowing you to choose between time display and a graph showing the measured values. Up to two parameters can be selected simultaneously.



9. Select the desired display options.
 - ⇒ When you select one or more measured values, the graph view opens, displaying the selected measured values as a function of time.

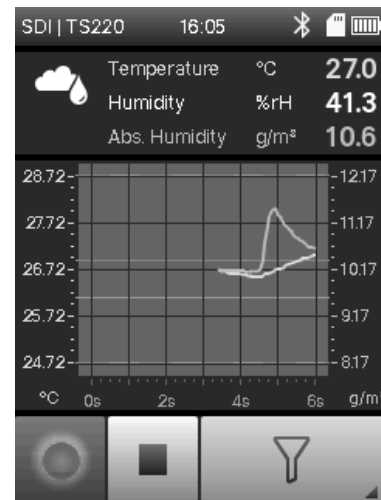

10. Tap the *Stop recording* button (65) in any of the views to end the recording.
 - ⇒ Recording will stop before the set time has elapsed and the collected data will be saved to the SD card.

Opening measurement data from the archive

Individual measured values and the results of continuous measurements can be viewed and deleted in the archive. To do so, please proceed as follows:

1. Open the *Archive* submenu.
 - ⇒ A list of folders is displayed in which the measured data is sorted by date of collection.

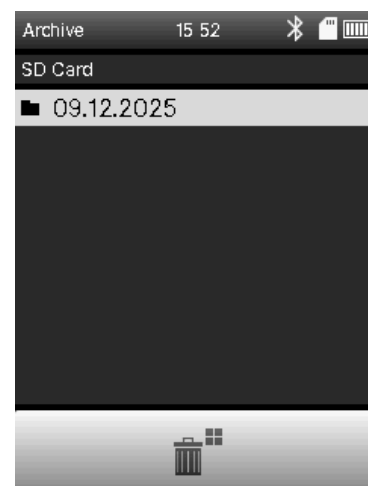

2. Open the folder with the desired date.

⇒ All recordings from the selected date are displayed in the form of a list.

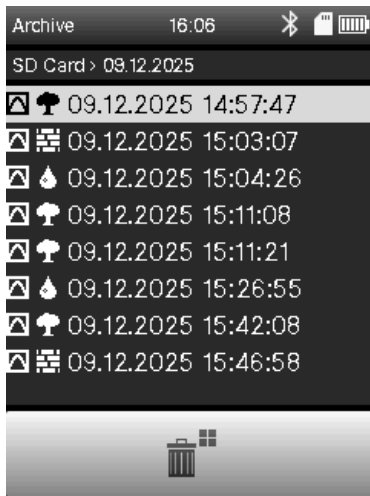

⇒ The detailed view of the recording opens.

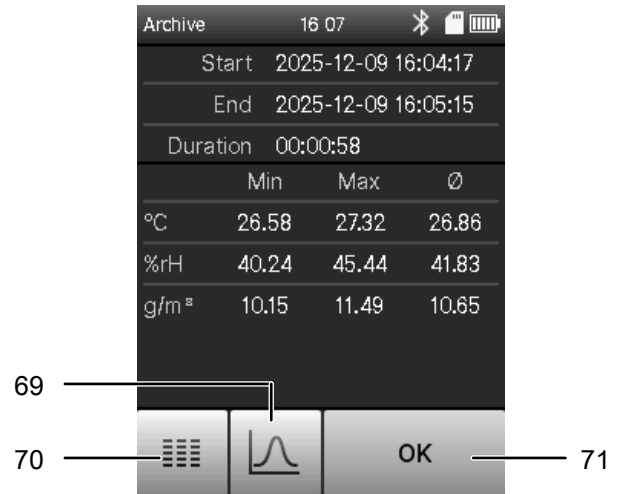

3. Open the desired recording.

- ⇒ A selection menu for the desired recording is displayed.
- ⇒ You have the option to delete the file (68) or view the measured values (67).

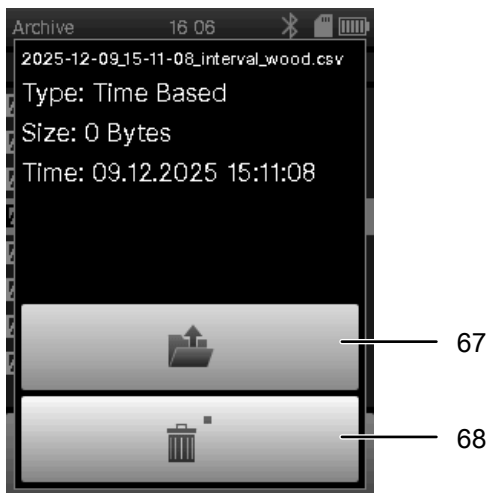

5. Open the list of individual measured values (70) or the display of measured values as a graph (69).

- ⇒ The selected detailed view opens.
- ⇒ You can filter the results by the measured variable (72) or zoom in on the graph (73).

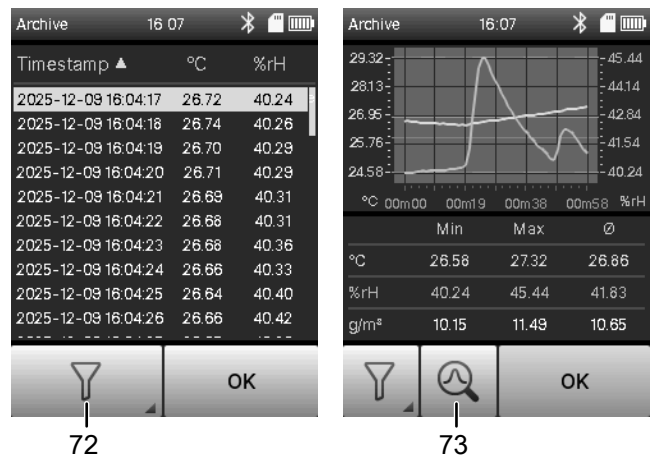

4. Open the file to view the details of the measured values.

6. Tap the *OK* button (71) or use the *Back* button (8) to close the detailed view of the recording.

Device settings

In the *Settings* submenu, you can configure the following device settings:

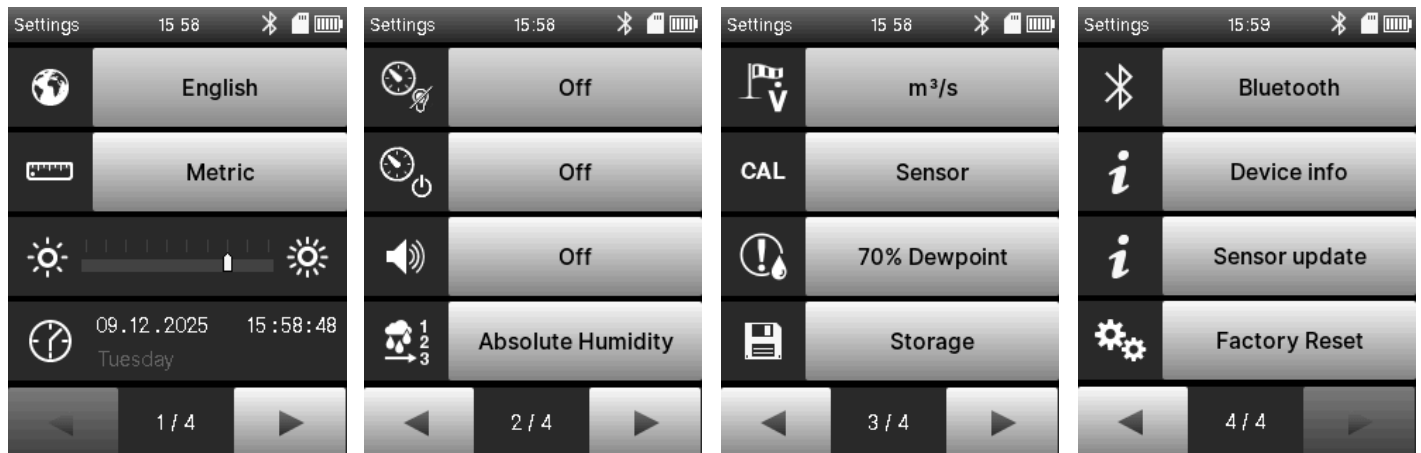

Icon	Submenu	Function	Icon	Submenu	Function
	<i>Language</i>	Setting the device language		<i>Volumetric flow</i>	Setting the unit for volumetric flow: m ³ /s, m ³ /min, m ³ /h, l/min
	<i>Units</i>	Switching between metric and imperial units		<i>CAL</i>	Sensor calibration/offset adjustment
	<i>Brightness</i>	Adjusting the display brightness		<i>Dew point temperature</i>	Opening the submenu for the temperature indication of the critical dew point. You can choose from the following options: <ul style="list-style-type: none"> • 100 %: The temperature of the calculated dew point will be displayed (100 % relative humidity). • 80 %: The temperature at 80 % relative humidity will be displayed as critical dew point. • 75 %: The temperature at 75 % relative humidity will be displayed as critical dew point. • 70 %: The temperature at 70 % relative humidity will be displayed as critical dew point.
	<i>Date and time setting</i>	Setting the date and time		<i>Memory</i>	Changing the storage location to either internal memory or microSD card
	<i>Screen saver</i>	Setting the timer for the screen saver		<i>Bluetooth</i>	Switching Bluetooth on or off
	<i>Automatic switch-off</i>	Setting the timer for automatic switch-off of the device		<i>Device info</i>	Information about the device and software version
	<i>Sounds</i>	Setting the signal sounds		<i>Sensor update</i>	Performing firmware updates for sensors
	<i>Calculated humidity parameters</i>	Selecting the base value to be displayed in measuring mode: Dewpoint: Displays the value as dew point. Absolute Humidity: Displays the value as absolute humidity in g/m ³ . Mixing Ratio: Displays the value as mixing ratio (g/kg) of the mass of steam to the mass of the dry gas.		<i>Reset</i>	Restoring the factory settings



Info

The term "critical dew point" specifies the temperature that is already critical for mould formation with regard to an associated relative humidity of approx. 70 %, 75 % or 80 %. Within these ranges, mould formation is already possible.

Therefore, the critical dew point is often several °C higher than the actual dew point temperature with 100 % RH, where condensation actually occurs!

Knowing the critical dew point is particularly important when carrying out measurements e.g. behind picture frames, closets or wardrobes in environments with otherwise inconspicuous room climate values.

Setting the language

1. From the main menu, select the *Settings* submenu.
2. Open the *Language* submenu.
3. Select the desired language in the following screen.
 - ⇒ The selected screen language is activated immediately.

English	Deutsch
Français	Español
Italiano	Türkçe
Dansk	Suomi
Svenska	Norsk
Dutch	Polski

Switching on Bluetooth

To use the MultiMeasure Mobile app, Bluetooth must first be turned on. The Bluetooth function is activated when the *Bluetooth* indication (15) is visible on the display. Please proceed as follows to activate the Bluetooth connection:

1. Open the *Settings* submenu.
2. Scroll to page 4.
3. Open the *Bluetooth* submenu.
 - ⇒ The window for setting up the Bluetooth connection opens.

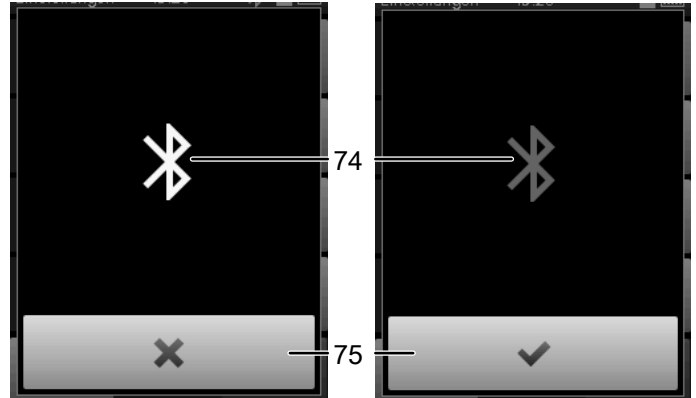

- ⇒ The Bluetooth icon (74) is white and the button (75) shows an "X" when Bluetooth is turned on.
 - ⇒ The Bluetooth icon (74) is greyed out and the button (75) shows a tick when Bluetooth is turned off.
4. Tap the button (75) to switch to the other setting.

4. Press the *Main menu* button (12) to return to the main menu.

MultiMeasure Mobile app



Install the Trotec MultiMeasure Mobile app on the terminal device you want to use in combination with the device.



Info

Some of the app's functions require access to your location and an active Internet connection.

The app is available for download in the Google Play Store as well as in Apple's app store and via the following link:



<https://hub.trotec.com/?id=43083>

Calibrating the sensor

The sensor is calibrated via the *Sensor* submenu in the *Settings*. From this menu, a single-point calibration (zero offset) can be carried out for the selected sensor indications. All sensors are already factory-calibrated and have a corresponding characteristic calibration curve. By specifying a calibration value (offset), a global shift of the calibration curve is performed for the single-point calibration, which has an effect on the entire measuring range.

The offset to be entered is the value by which the calibration curve will be shifted.

Example:

The displayed value is always 5 increments too high.

=> Change the offset value for this measurement channel by -5.

The offset value is set to 0.0 at the factory for most sensor types. Changing the offset value brings about an automatic reset of the measured values.

The offset value range depends on the respective sensor type and the unit to be measured. When entering values outside of the respective value range, a fault message stating the setting limits will be emitted. The shift will be saved by most SDI sensors and therefore also be considered for future measurements.

Please observe that in case of flow sensors the adjustment is effected by means of a factor. The default setting of the CAL value is 1.0 in this case, which corresponds to 100 %.

Example:

A setting of 0.9 would mean an adjustment to 90 % and therefore a reduction by 10 %. (measured value before: 10 m/s, after: 9 m/s).

A setting of 1.2 would mean an adjustment to 120 % and therefore an increase by 20 %. (measured value before: 10 m/s, after: 12 m/s)

Performing firmware updates

Updates can be carried out for both the sensors and the T4000.

To do so, please proceed as follows:

1. Establish a Bluetooth connection between the T4000 and the terminal device on which the MultiMeasure Mobile app is installed.
2. Open the MultiMeasure Mobile app.
 - ⇒ A notification window will open, informing you that a firmware update is available.
 - ⇒ You have the option to run the update now or postpone it until later.
3. Select the option to perform the update.
 - ⇒ The new firmware version is being installed.
 - ⇒ If firmware updates for sensors were included, a corresponding notification window will open after connecting the respective sensor, and you will again have the option to perform the update or postpone it until later.



Info

The update can also be downloaded from the Trotec website and transferred using the microSD card. Please contact the Trotec customer service for assistance.

Switching the device off

1. Press and hold the *Power* button (2) until the colour display turns off.
 - ⇒ The device is switched off.

Shutdown

1. Switch off the device by pressing the *Power* button (2, see section "Switching the device off").
2. Detach any connection cables and sensors.
3. Remove the batteries.
4. Clean the device according to the "Maintenance" chapter.
5. Store the device according to the "Storage" chapter.

MultiMeasure Mobile app

The T4000 can also be used with the MultiMeasure Mobile app. To do so, connect it to your terminal device via Bluetooth.

Connecting a measuring device

Proceed as follows to connect the measuring device to the terminal device:

- ✓ The Trotec MultiMeasure Mobile app is installed on your terminal device.
 - ✓ The Bluetooth function on your terminal device is activated.
 - ✓ The T4000 is switched on.
 - ✓ Bluetooth is enabled on the T4000.
1. Start the Trotec MultiMeasure Mobile app on the terminal device.
 2. Press the *Sensors* button (78) on the terminal device.
 - ⇒ The sensors overview opens.
 3. Press the *Refresh* button (77).
 - ⇒ If scan mode was not active before, the colour of the *Refresh* button (77) will change from grey to black. The terminal device will now search for all available sensors.
 4. Press the *Connect* button (76) to connect the T4000 to the terminal device.
 - ⇒ The measurement value display opens.
 - ⇒ The measuring mode opened on the T4000 is displayed.

Measurement value display

After selecting the sensor, the measurement value display opens.

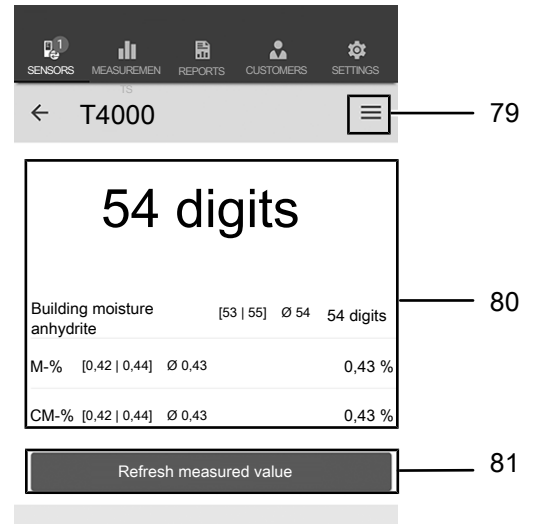

No.	Designation	Meaning
79	<i>Menu</i> button	Opens the menu to adjust the settings of the current measurement
80	Numeric <i>value</i> display	Displays the measured values collected by the connected sensor as well as average, maximum and minimum values
81	<i>Refresh measured value</i> button	Performs an individual measurement and refreshes the displayed values Note: Some sensors are automatically set to continuous measuring mode.

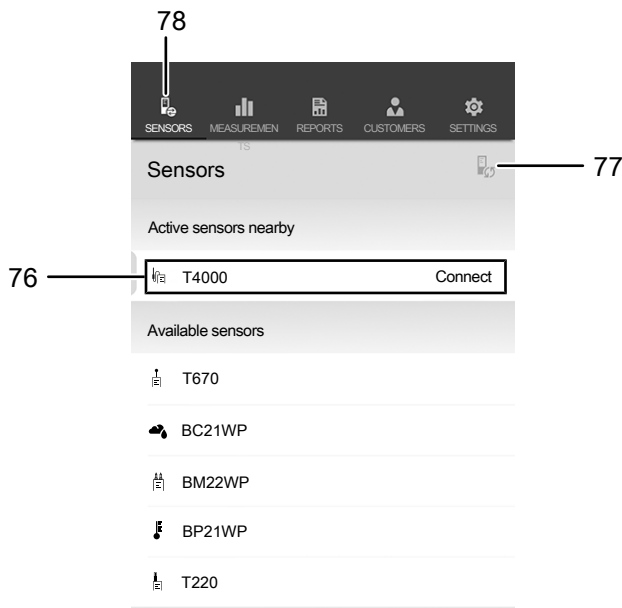

No.	Designation	Meaning
78	<i>Sensors</i> button	Opens the sensors overview
77	<i>Refresh</i> button	Refreshes the list of sensors near the terminal device
76	<i>Connect</i> button	Connects the displayed sensor to the terminal device

Measurement settings

The *Menu* button (79) opens options for adjusting the measurement settings. The available options may vary depending on the type of sensor connected.

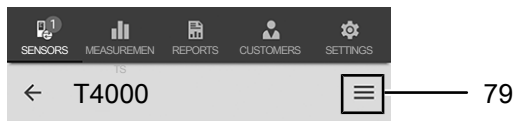

54 digits

Building moisture anhydrite [53 | 55] Ø 54 54 digits
 M-% [0,42 | 0,44] Ø 0,43 0,43 %
 CM-% [0,42 | 0,44] Ø 0,43 0,43 %

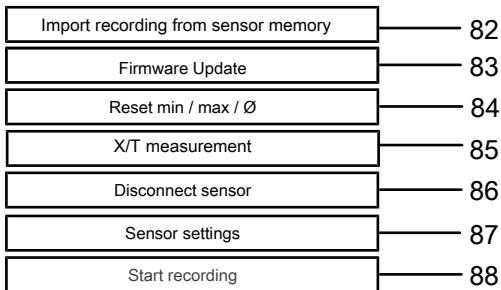

No.	Designation	Meaning
79	<i>Menu</i> button	Opens the menu for making settings for the current measurement
82	<i>Import recording</i> button	Imports recordings from the device's memory
83	<i>Firmware update</i> button	Performs a firmware update on the device
84	<i>Reset min / max / Ø</i> button	Deletes the determined values in (80)
85	<i>X/T measurement</i> button	Switches between continuous measurement and individual measurement Note: Available for some sensors only.
86	<i>Disconnect sensor</i> button	Disconnects the T4000 from the terminal device
87	<i>Sensor settings</i> button	Opens the settings menu for the connected device
88	<i>Start recording</i> button	Starts a recording of the determined measured values for later evaluation

Selecting material (when used with material moisture sensors)

Before you carry out a measurement you should select the material to be measured. To do so, please proceed as follows:

1. Press the *Menu* button (79).
⇒ The context menu opens.
2. Press the *Sensor settings* button (87).
⇒ The sensor settings menu opens.

Via the menu item *Features* you can select the desired material.

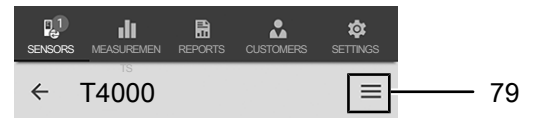

54 digits

Building moisture anhydrite [53 | 55] Ø 54 54 digits
 M-% [0,42 | 0,44] Ø 0,43 0,43 %
 CM-% [0,42 | 0,44] Ø 0,43 0,43 %

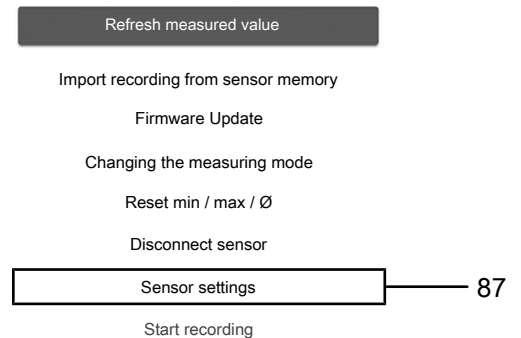

No.	Designation	Meaning
79	<i>Menu</i> button	Opens the menu for making settings for the current measurement
87	<i>Sensor settings</i> button	Opens the settings menu for the connected sensor

Recording measured values

Proceed as follows to record measured values for later evaluation:

1. Press the *Menu* button (79).
 - ⇒ The context menu opens.
2. Press the *Start recording* button (88).
 - ⇒ With most types of sensors, recording begins immediately.
 - ⇒ For material moisture sensors and pyrometers, a menu with various measurement methods is displayed:
 - individual spot measurement without image
 - individual spot measurement with image
 - matrix measurement without background image
 - matrix measurement with background image
3. Select one of the measurement methods by tapping the respective button on the terminal device.
 - ⇒ Recording begins.
 - ⇒ The *Menu* button (79) changes to the sensor icon and flashes while recording is in progress.

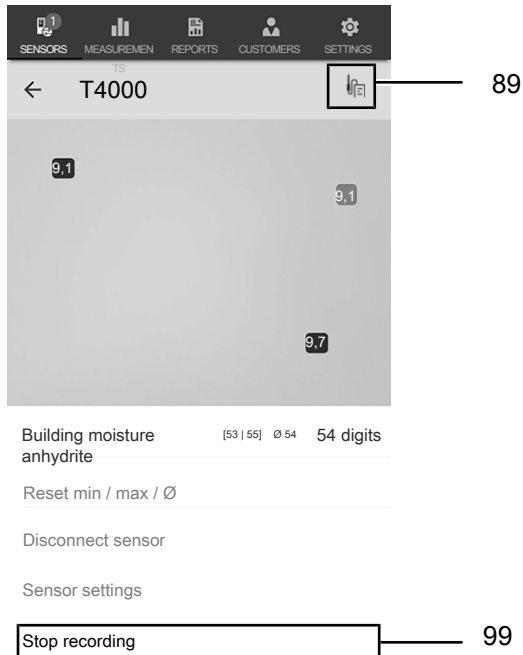

Performing an individual spot measurement without image

The individual spot measurement without image allows you to record several individual measuring points. To do so, please proceed as follows:

1. Repeatedly press the *Refresh measured value* button (81) until you have recorded all the required measured values.

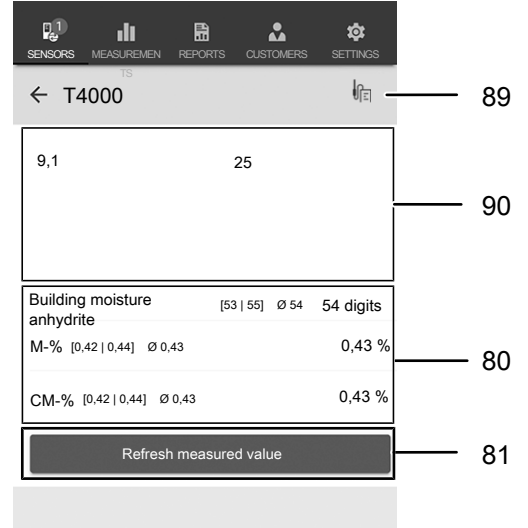

No.	Designation	Meaning
89	<i>REC</i> button	Opens the context menu for sensors
90	Measurement series indication	Measured values: Indicates the measured values in rows
80	Numeric <i>value</i> display	Displays the measured values collected by the connected sensor as well as average, maximum and minimum values
81	<i>Refresh measured value</i> button	Performs an individual measurement and refreshes the displayed values

Performing an individual spot measurement with image

If you have selected individual spot measurement with image, you will be prompted to choose whether you want to use a photo already saved in the mobile device's gallery or take a new one directly in the app. Choose an image section that best matches the measuring surface.

For measured value data logging please proceed as follows:

1. Tap the screen at the exact measuring location. The measured value will be displayed at this location.
 - ⇒ The measured value will be displayed in a specified grid on the background image. Pressing the *Shift measuring point* button (91) allows you to adjust the position of the measuring points. By pressing the *Shift measuring point* button (91) once more you can return to the measuring mode.

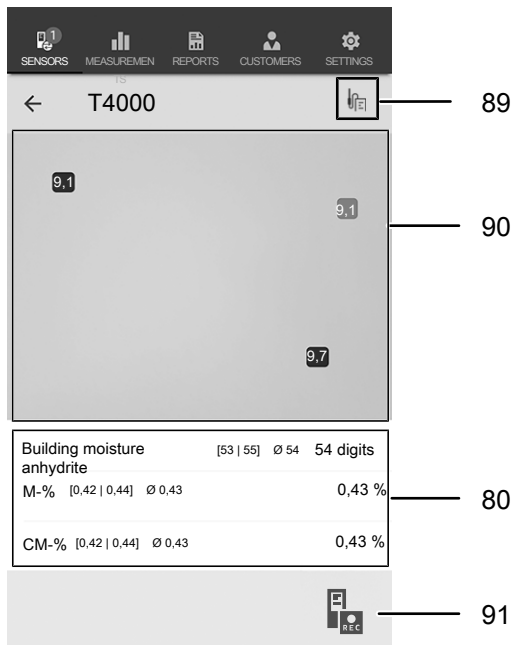

No.	Designation	Meaning
89	<i>REC</i> button	Opens the context menu for sensors
90	Measurement series indication	Measured values: Indicates the measured values in rows
80	Numeric <i>value</i> display	Displays the measured values collected by the connected sensor as well as average, maximum and minimum values
81	<i>Refresh measured value button</i>	Performs an individual measurement and refreshes the displayed values
91	<i>Shift measuring point button</i>	Stops the measured value data logging and allows you to relocate the measuring points on the background image

Performing a matrix measurement without background image

In case of a matrix measurement an entire series of measuring points is captured using a grid the size of which has to be selected.

1. Always start a matrix measurement in the top left corner (1st row, 1st column).
 - ⇒ The grid field to be measured flashes.
2. Perform the measurement in the flashing grid field.
3. Confirm the measured value by pressing the *Measured value data logging* button (93). You can reset a logged value by pressing *UNDO* (94). You can skip the indicated grid field and continue with the measurement in the next by pressing the *SKIP* button (95).
 - ⇒ The displayed measurement grid (92) moves on to the next line.
4. Perform the next measurement at the given point.
5. Press *NEW COLUMN* (96) when you have completed the measurements of all lines in one column so as to move on to the next.

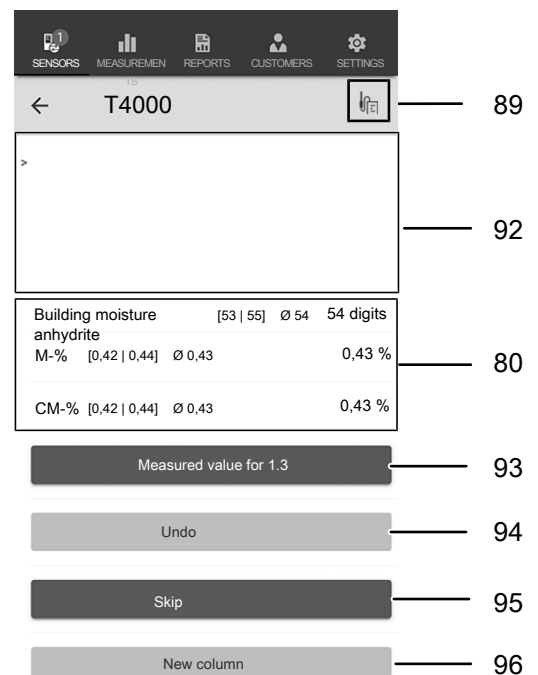

No.	Designation	Meaning
80	Numeric <i>value</i> display	Displays the measured values collected by the connected sensor as well as average, maximum and minimum values
89	<i>REC</i> button	Opens the context menu for sensors
92	Measuring field with grid	Indicates the measurement grid of the measuring field (grid field to be measured flashes red)
93	<i>Measured value data logging</i> button	Saves the measured value for the flashing grid field
94	<i>UNDO</i> button	Deletes the saved measured value for the respective grid field
95	<i>SKIP</i> button	Skips the grid field flashing red and moves on to the next grid field
96	<i>NEW COLUMN</i> button	Starts a new column

Performing a matrix measurement with background image

If you select a matrix measurement with background image, you will be prompted to choose whether you want to use a photo already saved in the mobile device's gallery or take a new one directly in the app. Choose an image section that best matches the measuring surface. You will then reach the settings menu for the measurement grid.

1. Adjust the grid's number of columns and lines by use of the slider (97).
2. Confirm the settings for the grid by pressing *Use* (98).

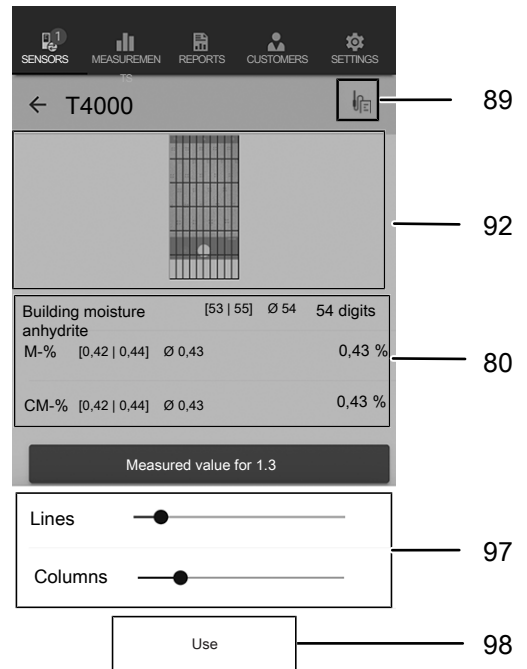

No.	Designation	Meaning
80	Numeric <i>value</i> display	Displays the measured values collected by the connected sensor as well as average, maximum and minimum values
89	<i>REC</i> button	Opens the context menu for sensors
92	Measuring field with grid	Indicates the measurement grid of the measuring field (with or without background image)
97	Slider	Changes the grid's number of columns and lines
98	<i>Use</i> button	Confirms the settings and leads to the measurement menu

Then start to carry out the measurements:

1. Always start a matrix measurement in the top left corner (1st row, 1st column).
 - ⇒ The grid field to be measured flashes.
2. Perform the measurement in the flashing grid field.
3. Confirm the measured value by pressing the *Measured value data logging* button (93). You can reset a logged value by pressing *UNDO* (94). You can skip the indicated grid field and continue with the measurement in the next by pressing the *SKIP* button (95).
 - ⇒ The displayed measurement grid (92) moves on to the next line.
4. Perform the next measurement at the given point.

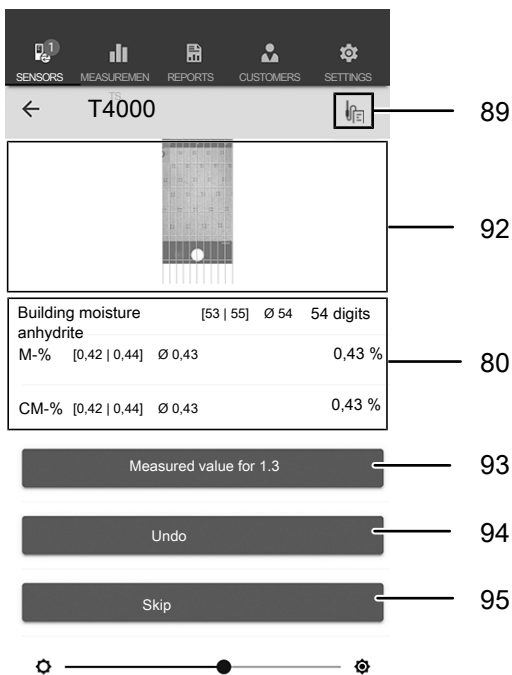

Info

By use of the slider you can optionally bring out either the background image or the grid.

Stopping a recording

Proceed as follows to stop recording the measured values:

1. Press the *REC* button (89).
 - ⇒ The context menu for sensors opens.
2. Press the *Stop recording* button (99).
 - ⇒ The context menu for saving the recording opens.
3. You can optionally save, discard or resume the measurement.

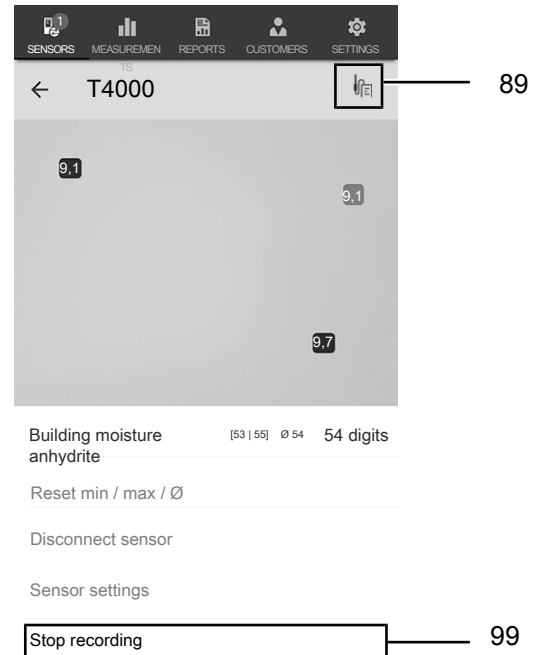

No.	Designation	Meaning
89	<i>REC</i> button	Opens the sensor settings menu
99	<i>Stop recording</i> button	Stops the current recording of measured values Opens the submenu for saving recordings

No.	Designation	Meaning
80	Numeric <i>value</i> display	Displays the measured values collected by the connected sensor as well as average, maximum and minimum values
89	<i>REC</i> button	Opens the context menu for sensors
92	Measuring field with grid	Indicates the measurement grid of the measuring field (grid field to be measured flashes red)
93	<i>Measured value data logging</i> button	Saves the measured value for the flashing grid field
94	<i>UNDO</i> button	Deletes the saved measured value for the respective grid field
95	<i>SKIP</i> button	Skips the grid field flashing red and moves on to the next grid field

Saving a recording

Proceed as follows to save the recorded measured values:

1. Press the *Save* button (100) to save the recorded measured values on the terminal device.
 - ⇒ The input mask for logging the recorded data opens.
2. Enter all the data relevant for an unambiguous assignment, then save the recording.
 - ⇒ The recording will be saved on the terminal device.

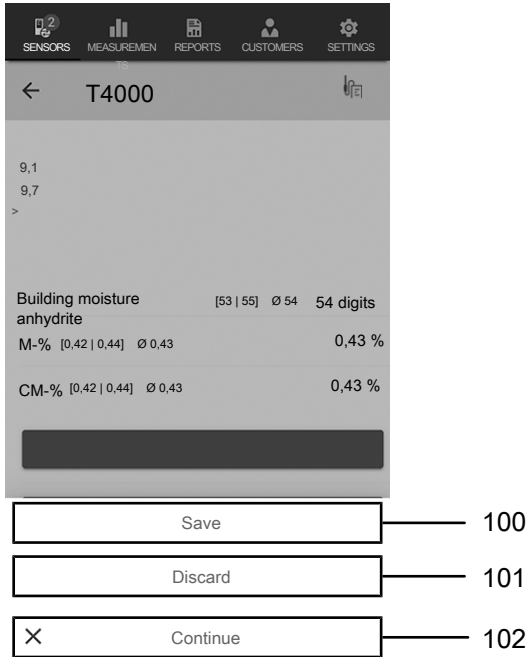

No.	Designation	Meaning
100	<i>Save</i> button	Stops the current recording of measured values Opens the input mask for logging recording data
101	<i>Discard</i> button	Stops the current recording of measured values Discards the recorded measured values
102	<i>Continue</i> button	Resumes the recording of the measured values without saving

Analysing measurements

Proceed as follows to call up the saved measurements:

1. Press the *MEASUREMENTS* button (103).
 - ⇒ An overview of already saved measurements will be displayed.
2. Press the *Display measurement* button (105) for the desired measurement to be indicated.
 - ⇒ A context menu for the selected measurement opens.

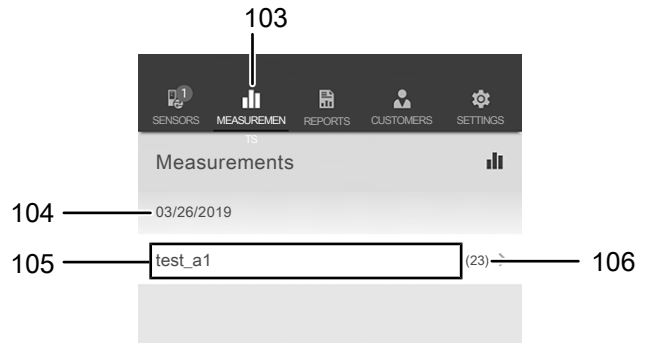

No.	Designation	Meaning
103	<i>MEASUREMENTS</i> button	Opens the overview of saved measurements
104	Indication of the <i>date of the measurement</i>	Indicates the date on which the measurement was recorded
105	<i>Display measurement</i> button	Opens the context menu for the selected measurement
106	Indication of the <i>number of measured values</i>	Indicates the number of individual measured values constituting the saved measurement

The following functions can be called up in the context menu of the selected measurement:

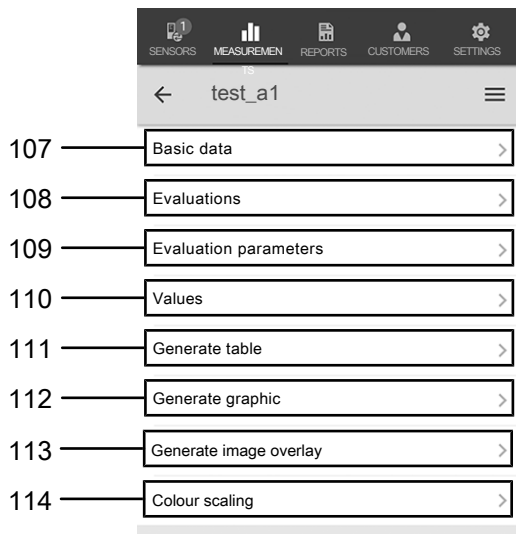

No.	Designation	Meaning
107	<i>Basic data</i> button	Opens an overview of the data saved for the measurement
108	<i>Evaluations</i> button	Opens an overview of the evaluations generated for the measurement (graphics and tables)
109	<i>Evaluation parameters</i> button	Opens a menu to select and deselect individual evaluation parameters
110	<i>Values</i> button	Opens a tabular overview of all logged values for the measurement
111	<i>Generate table</i> button	Creates a table containing the logged values of the measurement and saves it as a *.CSV file
112	<i>Generate graphic</i> button	Creates a graphic representation of the logged values and saves it as a *.PNG file
113	<i>Generate image overlay</i> button	Combines a background image with the coloured representation of the measured moisture values
114	<i>Colour scaling</i> button	Allows you to adjust the colour display of the measured moisture values

Generating a report

The reports generated in the MultiMeasure Mobile app are short reports providing a fast and simple documentation. Proceed as follows to generate a new report:

1. Press the *REPORTS* button (115).
⇒ The reports overview opens.
2. Press the *New report* button (116) to create a new report.
⇒ An input mask for entering all the relevant information opens.
3. Enter the information via the input mask and save the data.

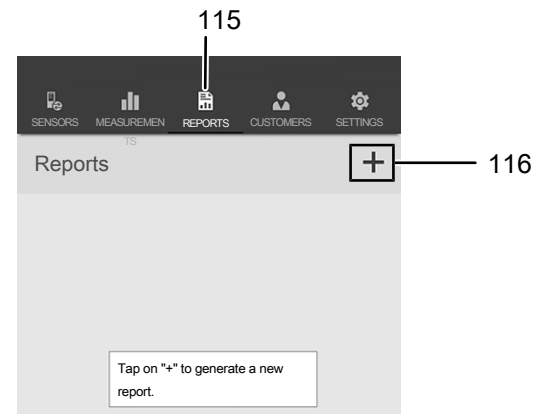

No.	Designation	Meaning
115	<i>REPORTS</i> button	Opens the overview of saved reports
116	<i>New report</i> button	Creates a new report and opens the input mask



Info

The customer can acknowledge the report directly in the integrated signature field.

Calling up a report

Proceed as follows to call up a created report:

1. Press the *REPORTS* button (115).
⇒ The reports overview opens.
2. Press the corresponding button (117) to display the desired report.
⇒ An input mask opens in which you can view and edit all the information.

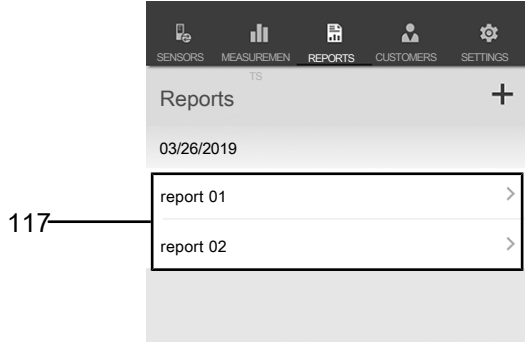

No.	Designation	Meaning
117	Display <i>REPORT</i> button	Opens the selected report

Creating a new customer

Proceed as follows to create a new customer:

1. Press the *CUSTOMERS* button (118).
⇒ An input mask for entering all the relevant information opens.
2. Enter the information via the input mask and save the data.
3. Alternatively, you can also import existing contacts from the phone book of the terminal device.



No.	Designation	Meaning
118	<i>CUSTOMERS</i> button	opens the overview of saved customers
119	<i>Add customer</i> button	Creates a new customer and opens the input mask

Calling up customers

Proceed as follows to call up an already created customer:

1. Press the *Customers* button (118).
⇒ An input mask opens in which you can view and edit all the information for the selected customer as well as directly start a new measurement.
⇒ The *New customer* button (119) changes. In this menu it can be used to delete the selected customer data record.

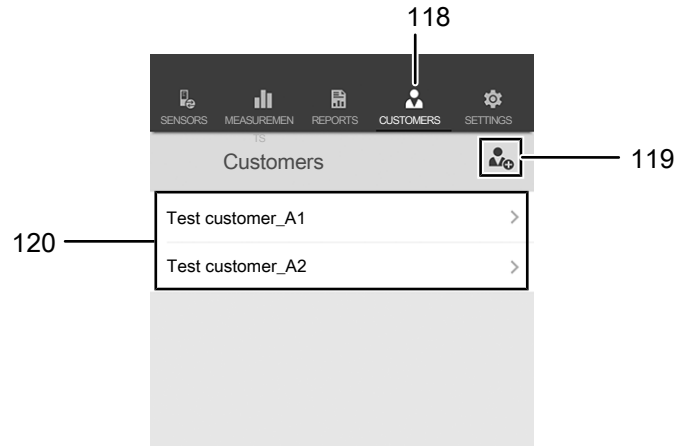

No.	Designation	Meaning
118	<i>CUSTOMERS</i> button	opens the overview of saved customers
119	<i>Add customer</i> button	allows you to delete the selected customer data record
120	<i>Customer X</i> button	opens the input mask for reading and changing the information for a saved customer



Info

You can perform a new measurement directly from the input mask.

App settings

Proceed as follows to make settings in the Trotec MultiMeasure Mobile app:

1. Press the *SETTINGS* button (121).
⇒ The settings menu opens.
2. Adjust the settings as required.

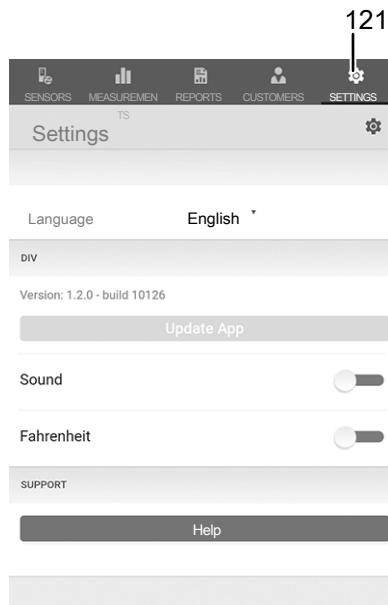

No.	Designation	Meaning
121	<i>SETTINGS</i> button	Opens the overview for the app settings and information

Disconnecting the measuring device

Proceed as follows to disconnect the T4000 from the terminal device:

1. Press the *Sensors* button (78).
⇒ A list of connected and available sensors will be displayed.
2. Select the line with the device to be disconnected and swipe left at the red marking.
3. Confirm your input.
⇒ The T4000 is now disconnected from the terminal device and can be switched off.
4. Alternatively, you can press the *Menu* button (79).
⇒ The context menu opens.
5. Press the *Disconnect sensor* button (86).
6. Confirm your input.
⇒ The T4000 is now disconnected from the terminal device and can be switched off.

Maintenance and repair

Battery change

Replace the batteries when the *Battery* indication (19) shows an empty battery and a warning signal is emitted, see section Inserting the batteries.

If the battery charge is completely depleted during operation, a warning message appears and a warning signal is emitted. In that case the device switches off after 5 seconds.

Cleaning

Clean the device with a soft, damp and lint-free cloth. Make sure that no moisture enters the housing. Do not use any sprays, solvents, alcohol-based cleaning agents or abrasive cleaners, but only clean water to moisten the cloth.

Clear dirt from the housing, the connections and the colour display.

Repair

Do not modify the device or install any spare parts. For repairs or device testing, contact the manufacturer.

Errors and faults

The device has been checked for proper functioning several times during production. If malfunctions occur nonetheless, check the device according to the following list.

The device does not switch on:

- Check the charging status of the batteries. Change them if required, see section Inserting the batteries.
- Check that the batteries are properly positioned. Check the polarity is correct.
- Never carry out an electrical check yourself; instead, contact your TROTEC® customer service.

The device runs but no measured values are shown:

- Check whether the multifunction measuring meter is in the correct sensor mode.
- Check the connection cable to the SDI or BNC sockets is connected properly.
- Check the used connection cable and its connections as well as the connections to the multifunction measuring meter for damages (e.g. broken cable, damaged pins etc.). Use a different connection cable of the same type to rule out possible faults.
- Ensure that the appropriate sensor for the measurement is being used. Here, also observe the Practice Handbook or the product catalogue for measuring devices.
- Ensure that the colour display is switched on. If necessary, press the "illumination on/off" button (see chapter "Device depiction").
- Check the room temperature and the relative humidity. Observe the device's permissible operating range according to the technical data.
- Check whether the multifunction measuring meter responds to touching the colour display. If it shows no reaction despite an enabled colour display and sufficient battery power, then the device firmware may have crashed. Restart the multifunction measuring meter. To do so, remove a battery and reinsert it.

Bluetooth connection is terminated or interrupted

- Check whether the *Bluetooth* indication is displayed. If so, switch the T4000 off and back on. Establish a new connection to the terminal device.
- Check the charging status of the batteries. Change them if required, see section Inserting the batteries.
- Does the distance between the T4000 and the terminal device exceed the radio range of the T4000(see chapter *Technical data*) or are there any solid building parts (walls, pillars etc.) situated between the T4000 and the terminal device? Shorten the distance between the two devices and ensure a direct line of sight.

The device cannot be connected to the terminal device although it is displayed there.

- Check the Bluetooth settings of your terminal device. A possible reason for this could be special, manufacturer-specific settings relating to an improved location accuracy. Enable these settings, then try to establish a connection to the device again.

Further information and assistance regarding the used sensor type will be provided in the MultiMeasure Mobile app via the menu item Settings => *Help*. Selecting the menu item *Help* opens a link to the app's help page. You can open a drop-down menu with numerous support entries from the *Table of contents*. Optionally, you can also scroll through the entire help page and thoroughly acquaint yourself with the individual help topics.

Your device still does not operate correctly after these checks?

Contact your Trotec customer service.

Disposal

Always dispose of packing materials in an environmentally friendly manner and in accordance with the applicable local disposal regulations.



The icon with the crossed-out wheeled bin indicates that this device and any associated components (e.g. remote controls) must not be disposed of with household waste at the end of their life, in accordance with the Waste Electrical and Electronic Equipment Directive (2012/19/EU) and national laws.

You will find collection points for free return of waste electrical and electronic equipment in your vicinity. The addresses can be obtained from your municipality or local administration. You can also find out about other return options that apply for many EU countries on the website <https://hub.trotec.com/?id=45090>. Otherwise, please contact an official recycling centre for electronic and electrical equipment authorised for your country.

The separate collection of waste electrical and electronic equipment aims to enable the re-use, recycling and other forms of recovery of waste equipment as well as to prevent negative effects for the environment and human health caused by the disposal of hazardous substances potentially contained in the equipment.



This icon with the crossed-out wheeled bin indicates that batteries or accumulators must not be disposed of with household waste at the end of their life. If the device contains batteries or accumulators that contain mercury, cadmium or lead, the respective chemical symbol (Hg, Cd or Pb) is shown below the icon of the crossed-out wheeled bin. To prevent environmental pollution, do not carelessly leave batteries or electrical and electronic equipment containing batteries in public areas. In the European Union, batteries and accumulators must be returned to a designated collection point in accordance with REGULATION (EU) 2023/1542 OF THE EUROPEAN PARLIAMENT AND OF THE COUNCIL of 12 July 2023 concerning batteries and waste batteries. Remove batteries/accumulators and dispose of them separately according to the relevant legal requirements.

Only for United Kingdom

According to Waste Electrical and Electronic Equipment Regulations 2013 (SI 2013/3113) (as amended) and the Waste Batteries and Accumulators Regulations 2009 (SI 2009/890) (as amended), devices that are no longer usable must be collected separately and disposed of in an environmentally friendly manner.

Declaration of conformity

We – Trotec GmbH – declare in sole responsibility that the product designated below was developed, constructed and produced in compliance with all relevant provisions of the EU Radio Equipment Directive in the version 2014/53/EU.

Product model / Product: T4000

Product type: multifunction measuring meter

Year of manufacture as of: 2026

The product also complies with all relevant provisions of the following directives/regulations:

- 2011/65/EU
- 2014/30/EU

Other EU legal acts applied:

- 2012/19/EU

Applied harmonised standards:

- EN 300 328 V2.2.2
- EN 301 489-1 V2.2.3:2019-11
- EN 301 489-17 V3.3.1:2024-09
- EN 61010-1:2010 + A1:2019 + A1:2019/AC:2019

Applied national standards and technical specifications:

- EN 55032:2015 + AC:2016 + A11:2020 + A1:2020
- EN 61000-4-29:2000
- EN 61000-4-8:2010
- EN 61326-2-1:2013
- EN IEC 61000-4-11:2020
- EN IEC 61000-6-2:2019
- EN IEC 61000-6-4:2019

Manufacturer and name of the authorised representative of the technical documentation:

Trotec GmbH

Grebber Straße 7, D-52525 Heinsberg

Phone: +49 2452 962-0

E-mail: online@trotec.com

Place and date of issue:

Heinsberg, 01.01.2026



Joachim Ludwig, Managing Director

Trotec GmbH

Grebener Str. 7
52525 Heinsberg
Germany

☎ +49 2452 962-0

☎ +49 2452 962-200

✉ online@trotec.com

www.trotec.com